

Progressive scan CCD color camera KP-FD510WCL Specifications (Preliminary)

1. General

The KP-FD510WCL is single CCD type RGB color camera which utilized the progressive scan CCD image sensor with square pixel for 5.0M format of 2/3-inch which adopted the RGB primary color mosaic filter.

The non-interlaced image of 2448 (H) x 2050 (V) is output at 12 frames per second.

The square lattice pixel format also provides excellent suitability for image processing applications.

2. Outstanding features

(1) High resolution and high color fidelity

The 2/3-inch 5,000,000 pixels square lattice progressive scan CCD and the RGB primary color mosaic filter achieve a high resolution and high color fidelity of 2448(H) x 2050(V)

(2) Small sized camera

The camera has small SDR connector for digital outputs.

Therefore, the camera has the realization of small-sized shape of 44 (W) x 44 (H) x 41 (D) mm.

(3) Remote control

- Multi-step electronic shutter (from 1/12 to 1/50000 second in 8 steps)

- Variable shutter (from 10 to 1/100000 second)

- Frame on demand (the image capture at desired timing using the external trigger signal)

- White balance (ATW, Manual and One-push)

- 6 vector independent masking (R, G, B, Cy, Mg, Ye can be independently varied)

and other various functions are set by remote control via CameraLink cable.

(4) Automatic power supply change

The power supply through the camera link cable is possible from the PoCL frame grabber board. Because the power supply from the DCIN/SYNC connector is also possible, it is possible to make the camera work by using usual frame grabber board. The power supply from the DCIN/SYNC connector is given to priority when the power supply is supplied from both.

-	Aug.30,2013	(first edition)					K.UENO	K.UENO		
SYMBOL	DATE	DESCRIPTION					(DRAWN)	DESIGNED		

MODEL KP-FD510WCL				TOLERANCE		Prod. Code - Order No.				
DESIGNED	DATE	APPROVED	DATE	UNIT		TITLE KP-FD510WCL Specifications			REV. 0	
CHECKED	DATE	STORED	DATE							
Hitachi Kokusai Electric										

3. Specifications

A	(1) Imaging device	2/3-inch progressive scan interline CCD	A
	Total pixels	2536(H) x 2068(V)	
	Effective pixels	2456(H) x 2058(V)	
	Pixel size	3.45 um (H) x 3.45 um (V) (square lattice)	
	Color filter	RGB primary color mosaic filter	
B	(2) Sensing area	8.45 mm (H) x 7.07 mm (V)	B
	(3) Scanning system	Progressive	
	(4) Aspect ratio	5 : 4	
	(5) Frame rate	12 frames per second (full pixel readout)	
	(6) Horizontal drive frequency	48.0000 MHz	
	(7) Horizontal scanning frequency	24.922 kHz	
	(8) Vertical scanning frequency	11.99 Hz	
	(9) Sync system	Internal	
	(10) Lens mount	C mount	
	(11) Flange focal distance	17.526 mm	
C	(12) Video output		C
	Interface	CameraLink 64.0000 MHz Base configuration (1ch:SDR connector x 1pc.) Medium configuration (2ch:SDR connector x 2pcs)	
D	Output format	(a) 24bit (R:8bit G:8bit B:8bit) (Base configuration) (b) 30bit (R:10bit G:10bit B:10bit) (Medium configuration) (c) 36bit (R:12bit G:12bit B:12bit) (Medium configuration)	D
	Output Image size	2448 (H) x 2050 (V) (full pixel readout)	
	(13) Sensitivity	2000 lx, F8, 3200 K	
	(14) Minimum lamination	15 lx (F1.4, MAX GAIN)	
	(15) Signal noise to ratio	48 dB	
	(16) Electric shutter	OFF, 1/12, 1/60, 1/100, 1/250, 1/1000, 1/2000, 1/10000, 1/50000 second OFF is normal exposure (frame rate) or changeable by variable shutter (from 10 to 1/100000 second)	
E	(17) Frame on demand		E
	Mode	(A) Fixed shutter mode (8 steps or variable) (B) ONE trigger mode (C) VD reset mode	
	Trigger input	CameraLink (CC1) or DCIN/SYNC connector	
F			F

A	(18) Partial scan		Selectable start position and width of picture grabbing in 1H step.	A	
	(19) ALC (Auto level control) Mode		AGC (Auto gain control) AES (Auto electric shutter) AGC & AES		
B	Video level		Adjustable	B	
	(20) Gain		Auto/Manual (0 to +12dB) (Approx. 0.0358dB step)		
	(21) White balance		ATW / MANUAL / One-push		
	(22) Gamma		OFF ($\gamma=1$) / LUT		
	(23) Color masking		OFF / ON (6 vector independent masking)		
	(24) Paint black		Adjustable		
	(25) Sharpness		Adjustable		
	(26) Brightness		Adjustable		
C	(27) Knee		Adjustable	C	
	(28) Power supply voltage		12 \pm 1 VDC		
	(29) Current consumption		Approx. 240 mA (Approx. 2.88W)		
	(30) Ambient	Performance			0 to +40 °C (+32 to +104 F), less than 90 % RH
		Operation			-10 to +50 °C (+14 to 122 F), less than 90 % RH
Storage			-20 to +60 °C (-4 to 140 F), less than 70 % RH (without dew condensation)		
D	(31) Vibration endurance		10 to 55 Hz (2.37 to 71.7 m/s ²), sweep: 1 min XYZ 30min	D	
	(32) Shock endurance		490.3 m/s ²		
			(Drop test, once each top, bottom, left and right)		
	(33) External dimensions		44 (W) x 44 (H) x 41 (D) mm (Not including mount protrusions)		
E	(34) Mass		Approx. 110 g	E	
F				F	

(35) Remote control

(a) Signal system

Control system	Start-stop synchronization system
Transmission rate	9600 bps
Data length	8 bits
Start bit	1bit
Stop bit	1bit
Parity	None
Bit transfer	LSB first

(b) Communications control system

Full control by remote control software, data send/receive by text data transfer to camera microprocessor (BSC system handshake)

(c) Control items

1. Shutter speed	OFF, 1/12, 1/60, 1/100, 1/250, 1/1000, 1/2000, 1/10000, 1/50000 second Factory setting: OFF
2. Variable shutter	10 to 1/100000 second
3. Mode	OFF, Fixed shutter, ONE trigger and VD reset mode Factory setting: OFF
4. Gain	0 to 12 dB (Approx. 0.0358 dB step) Factory setting: 0 dB
5. ALC	
6. White balance	
7. Gamma	
8. 6 vector independent masking	
9. Paint black	
10. Sharpness	
11. Brightness	
12. Knee	
13. Partial scan	Factory setting: OFF
14. VD/FVAL	Factory setting: FVAL
15. HD/LVAL	Factory setting: LVAL
16. 24bit/30bit/36bit	Factory setting: 24bit
17. Trigger pulse polarity	POS (high active) or NEG (low active) Factory setting: POS
18. Trigger input	CameraLink (CC1) or DCIN/SYNC connector Factory setting: CC1
19. Output Signal	OFF, FLASH OUT and VD OUT Factory setting: OFF

4. Composition

(1) Camera (with IR cut filter)

5. Optional accessories

- | | |
|-----------------------------|---------------------------------|
| (1) Dummy glass (AR coated) | ARC1214 |
| (2) IR cut filter | IRC650 |
| (3) Junction box | JU-F30 |
| (4) Tripod adaptor | TA-F500 |
| (5) 12 pin plug | HR10A-10P-12S(01) or equivalent |
| (6) Camera cable | |

	Molded type	Shield type
2 m	C-201KSM	C-201KSS
5 m	C-501KSM	C-501KSS
10 m	C-102KSM	C-102KSS

In the CE Marking region, use the shield type and install clamp filter (ZCAT2035-0930A: TDK) at both ends of the cable.

(7) Digital out cable

Cable length	Model name	
	SDR-SDR type	SDR-MDR type
1m	C-101PCL (SS)	C-101PCL (SM)
2m	C-201PCL (SS)	C-201PCL (SM)
3m	C-301PCL (SS)	C-301PCL (SM)
5m	C-501PCL (SS)	C-501PCL (SM)

SDR: Shrunk Delta Ribbon

MDR: Miniature Delta Ribbon

6. Specification of Digital output connector

(1) DCIN/SYNC connector

PIN No.	Internal SYNC mode	PIN No.	Internal SYNC mode
1	GND	7	Trriger IN / VD IN
2	------(PoCL)	8	GND
	+12V(non-PoCL)		
3	GND	9	_____
4	_____	10	FLASH OUT / VD OUT
5	GND	11	_____
6	_____	12	GND

Plug (matching cable plug) Hirose HR10A-10P-12S(01) or equivalent

(Note) Please do not unplug and insert cable (camera cable) with a power supplied to a camera.
Install clamp filter (ZCAT 2035-0930A: TDK) at both ends (camera and video processor ends) in the CE marking region.

(2) DIGITAL OUT connector

(a) Relation between number of output data bit and used connector

	Number of data bit	D.OUT1	D.OUT2
1	24bit (R:8bit G:8bit B:8bit)	Use	Not use
2	30bit (R:10bit G:10bit B:10bit)	Use	Use
3	36bit (R:12bit G:12bit B:12bit)	Use	Use

(b) Signal connection to DIGITAL OUT connector

D.OUT1 (use for 24bit / 30bit / 36bit)

Pin No.	Signal	Pin No.	Signal
1	+12V(PoCL)	14	GND
	GND(non-PoCL)		
2	TXOUT 0 (-)	15	TXOUT 0 (+)
3	TXOUT 1 (-)	16	TXOUT 1 (+)
4	TXOUT 2 (-)	17	TXOUT 2 (+)
5	TXCLKOUT (-)	18	TXCLKOUT (+)
6	TXOUT 3 (-)	19	TXOUT 3 (+)
7	RX (+) [SERTC (+)]	20	RX (-) [SERTC (-)]
8	TX (-) [SERTFG (-)]	21	TX (+) [SERTFG (+)]
9	TRIG/VD (-) [CC1 (-)]	22	TRIG/VD (+) [CC1 (+)]
10	N.U. [CC2 (+)]	23	N.U. [CC2 (-)]
11	N.U. [CC3 (-)]	24	N.U. [CC3 (+)]
12	N.U. [CC4 (+)]	25	N.U. [CC4 (-)]
13	GND	26	+12V(PoCL)
			GND(non-PoCL)

D.OUT2 (use for 30bit / 36bit)

Pin No.	Signal	Pin No.	Signal
1	+12V(PoCL)	14	GND
	GND(non-PoCL)		
2	TYOUT 0 (-)	15	TYOUT 0 (+)
3	TYOUT 1 (-)	16	TYOUT 1 (+)
4	TYOUT 2 (-)	17	TYOUT 2 (+)
5	TYCLKOUT (-)	18	TYCLKOUT (+)
6	TYOUT 3 (-)	19	TYOUT 3 (+)
7	N.U.	20	N.U.
8	N.U.	21	N.U.
9	N.U.	22	N.U.
10	N.U.	23	N.U.
11	N.U.	24	N.U.
12	N.U.	25	N.U.
13	GND	26	+12V(PoCL)
			GND(non-PoCL)

Connector (camera side) Sumitomo 3M 1226-1100-00PL or equivalent

N.U.: Not used

- D.OUT2 is used for Medium configuration.
- The digital out cable should be comprised of a twisted pair of wires having 100 ohm characteristic impedance and an outer sheath shield type conductor.
- Connect the shield (GND) of the digital out cable to the ground terminal of the video equipment, frame grabber, etc.
- Install clamp filter (ZCAT2035-0930A: TDK) at both ends (camera and video processor ends) in the CE marking region.
- TX: Transmit data from camera to machine
- RX: Transmit data from machine to camera

(Note) Please do not unplug and insert cable(digital out cable) with a power supplied to a camera.

7. CameraLink output

7-1. Horizontal timing

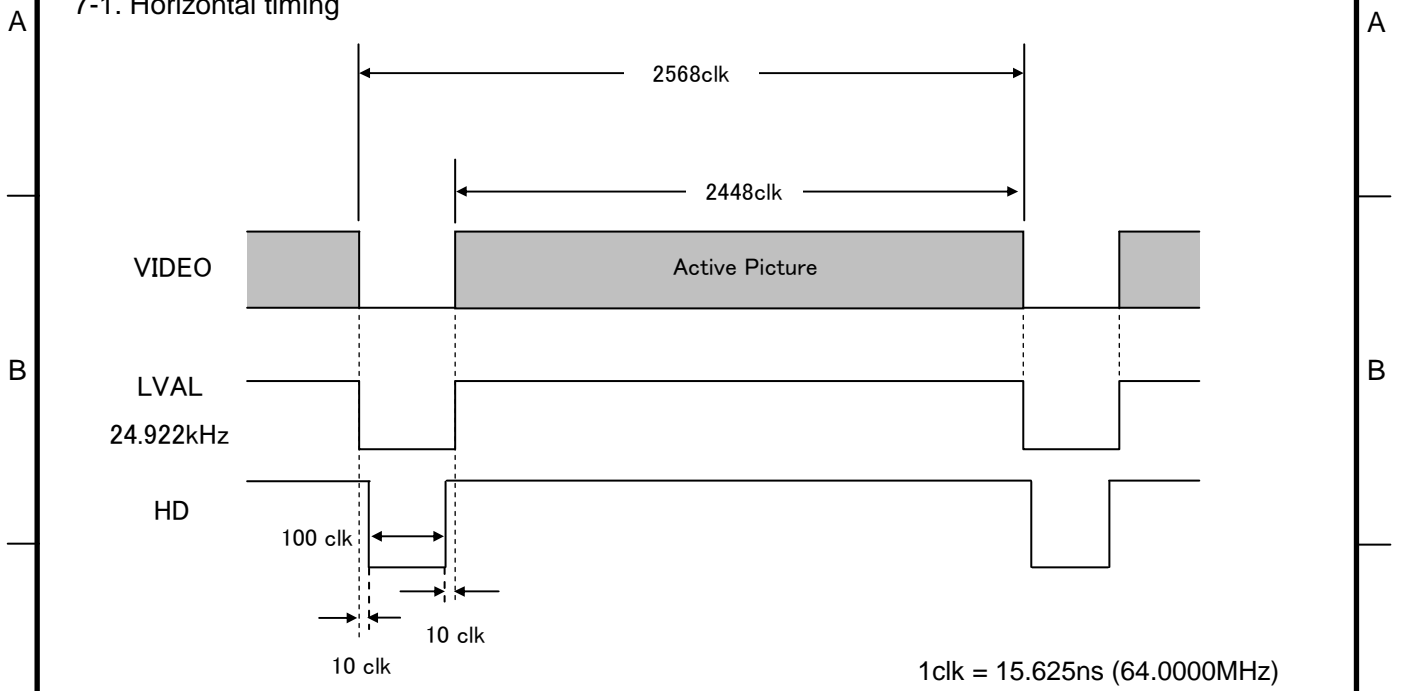

7-2. Vertical timing

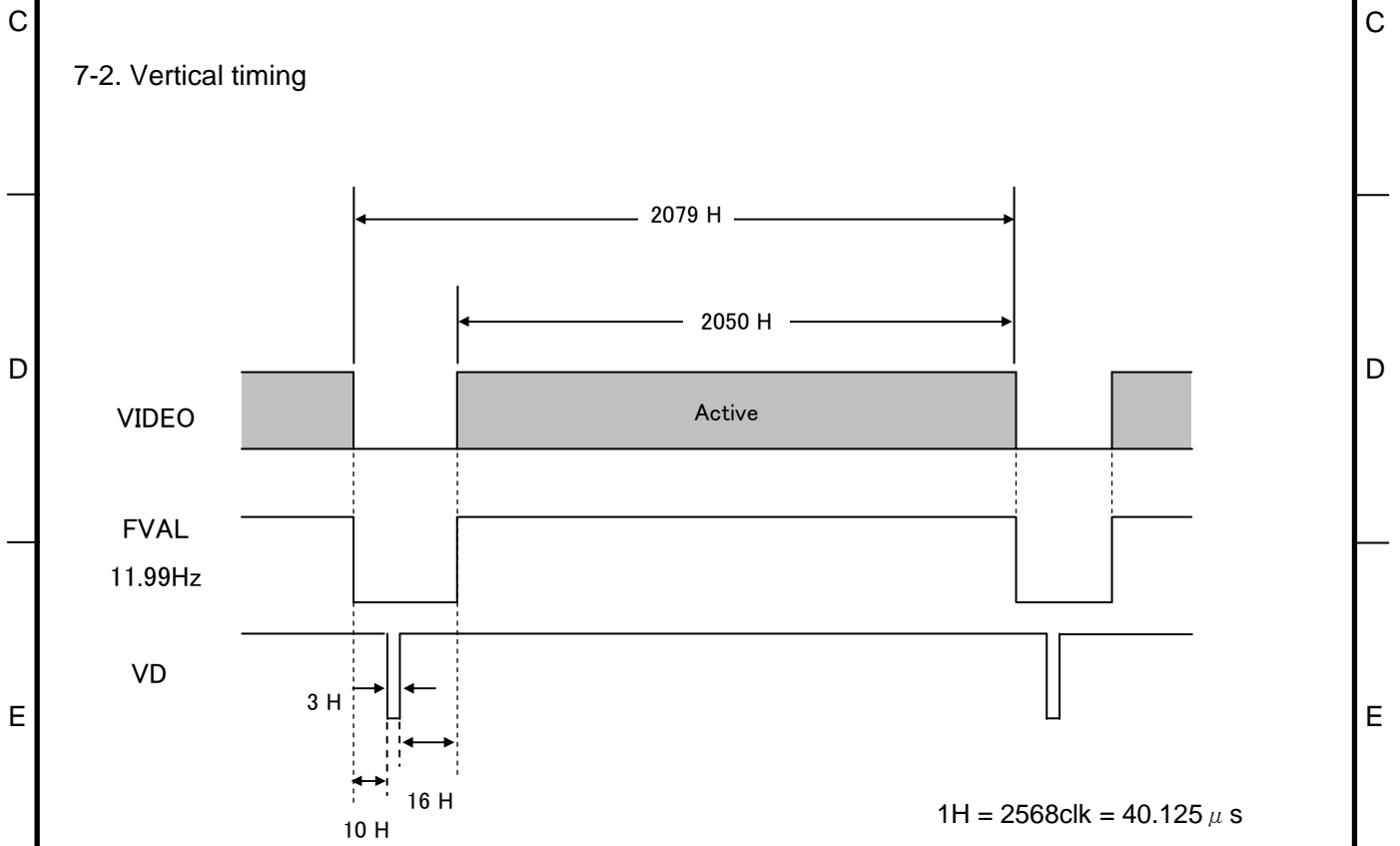

7-3. Transmitter LVDS output pulse position measurement

(1) Base configuration 24bit

D.OUT 1

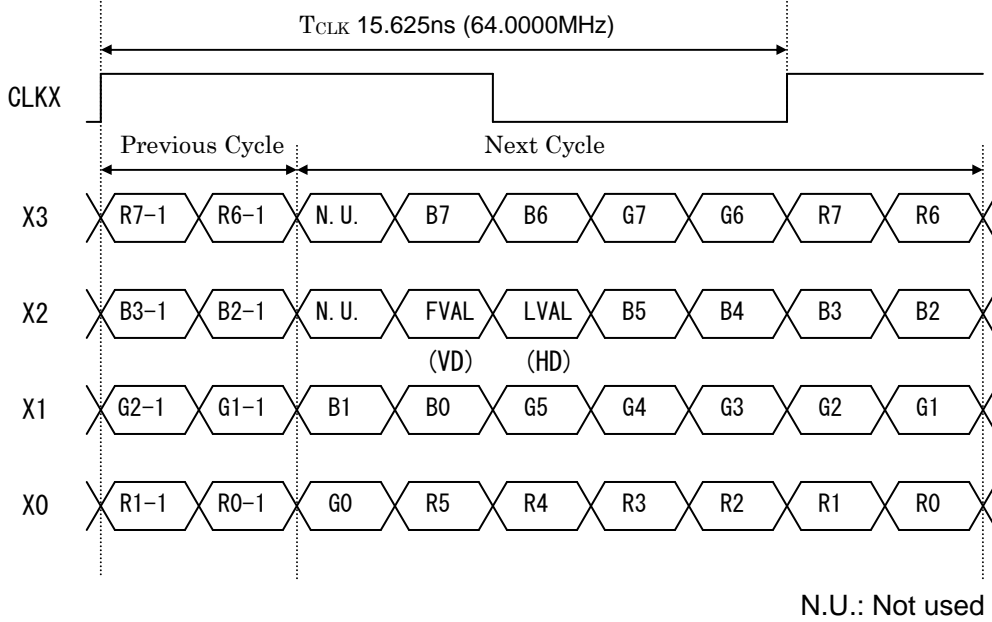

* When using Base configuration, please be sure to connect to CameraLink cable to D.OUT1.
 If the cable is connected to D.OUT2, the machine may break down.

(2) Medium configuration 30bit

D.OUT 1

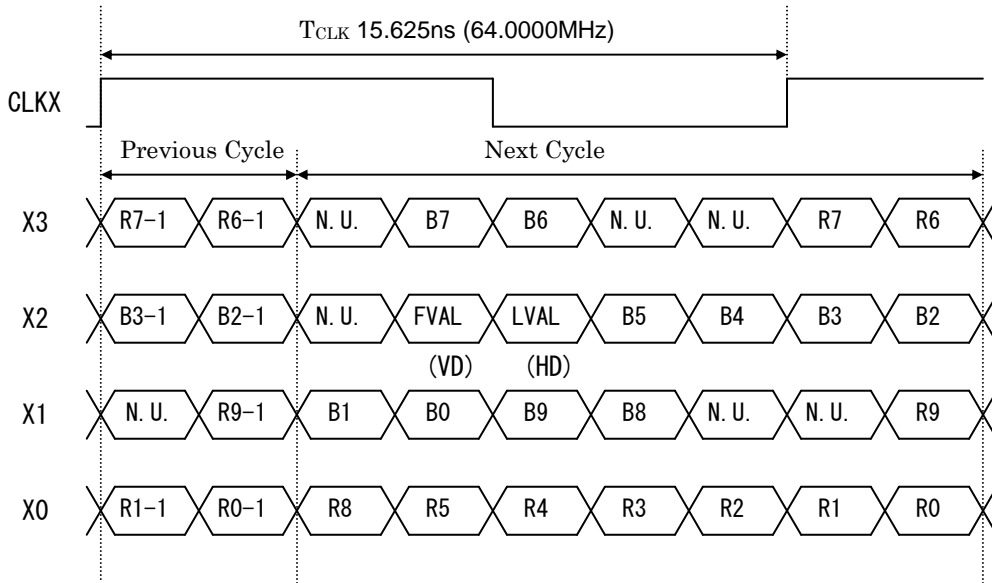

N.U.: Not used

D.OUT 2

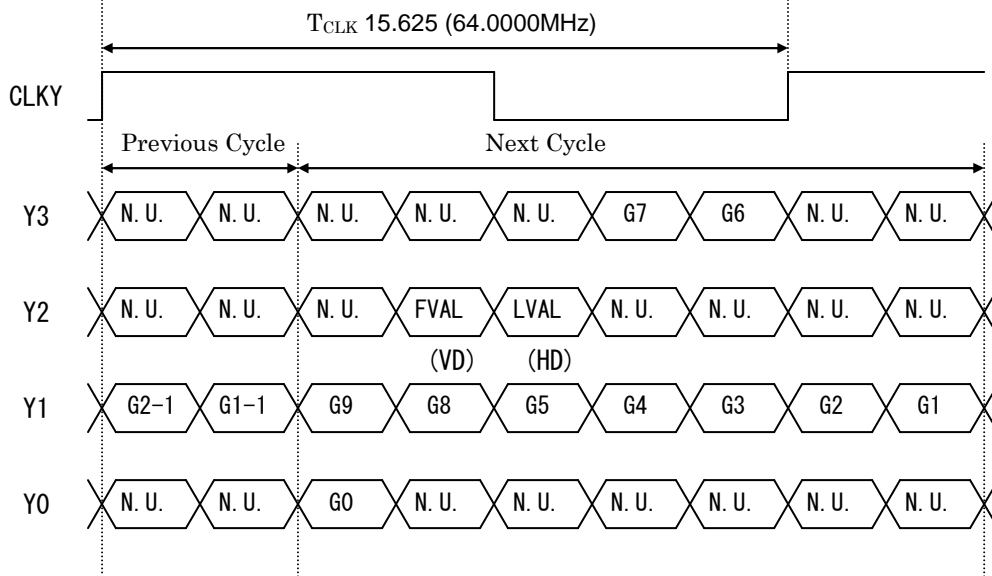

N.U.: Not used

(2) Medium configuration 36bit

D.OUT 1

A

A

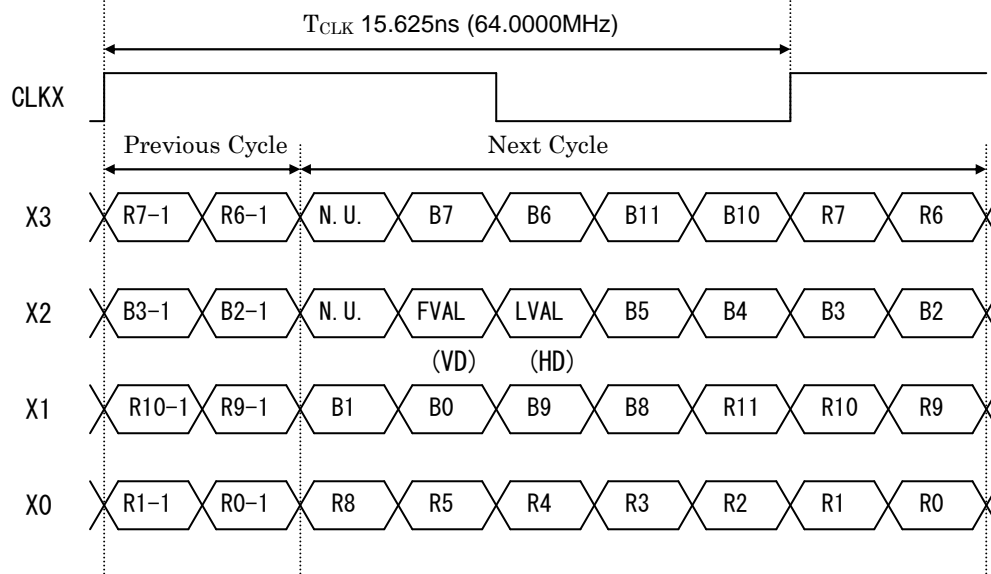

N.U.: Not used

C

C

D.OUT 2

D

D

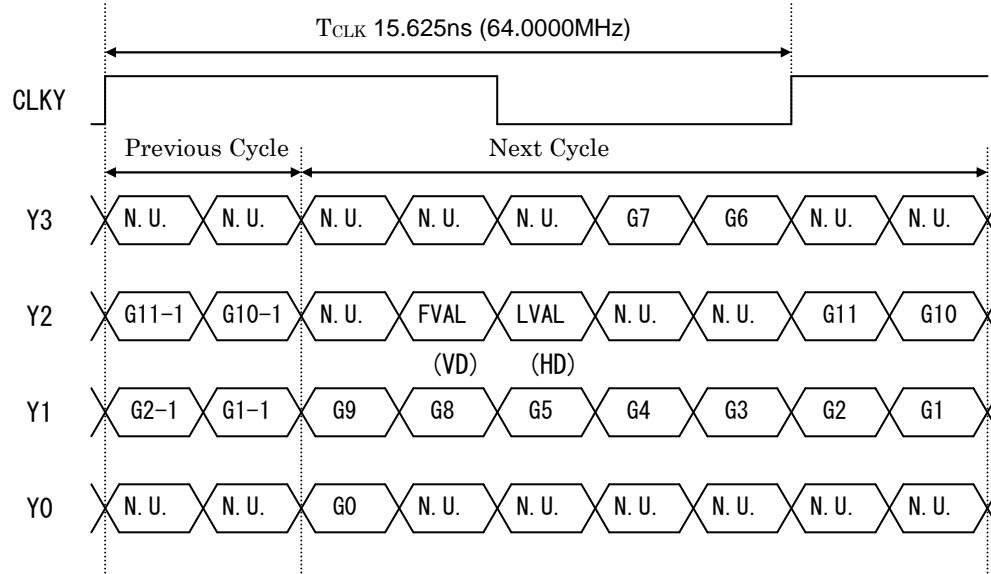

N.U.: Not used

F

F

8. Timing chart

8-1. Normal mode

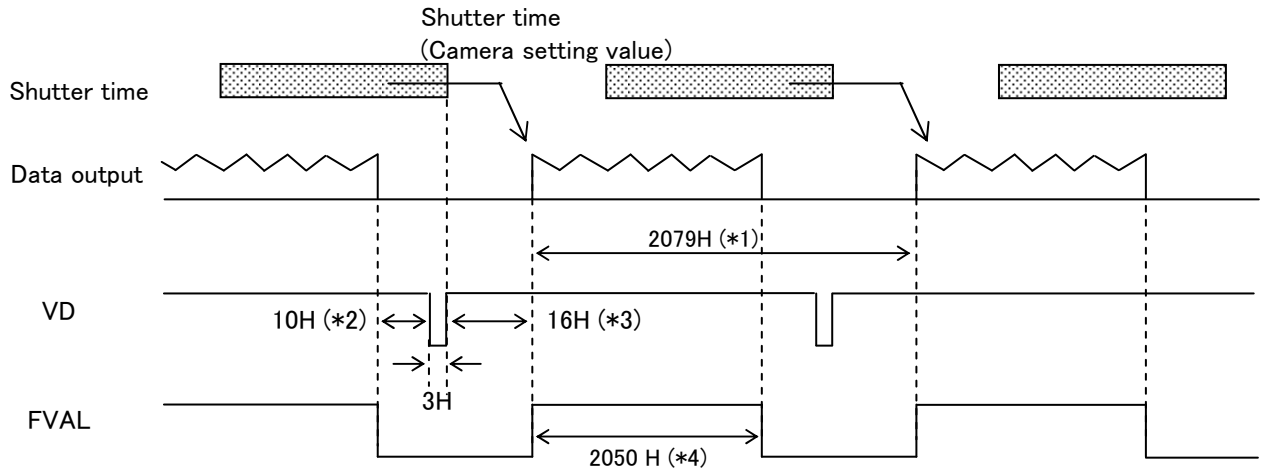

1H = 2568clk = 40.125 μs

When partial scan is ON, *1 to *4 are variable by start position of picture grabbing and width of picture grabbing (omit the figures after the decimal fractions).

*1: $(20 + \text{Width} + (2071 - \text{Width}) / 4)H$

*2: $(1 + (2071 - \text{Width}) / 4 - \text{Start} / 4)H$

*3: $(16 + \text{Start} / 4)H$

*4: $(\text{Width})H$

Note1: Please use the partial scan in following condition.

$\text{Start} + \text{Width} \leq 2051$

Note2: Please use FVAL in the partial scan.

Graph following shows frame rate in each of picture grabbing in the partial scan mode.

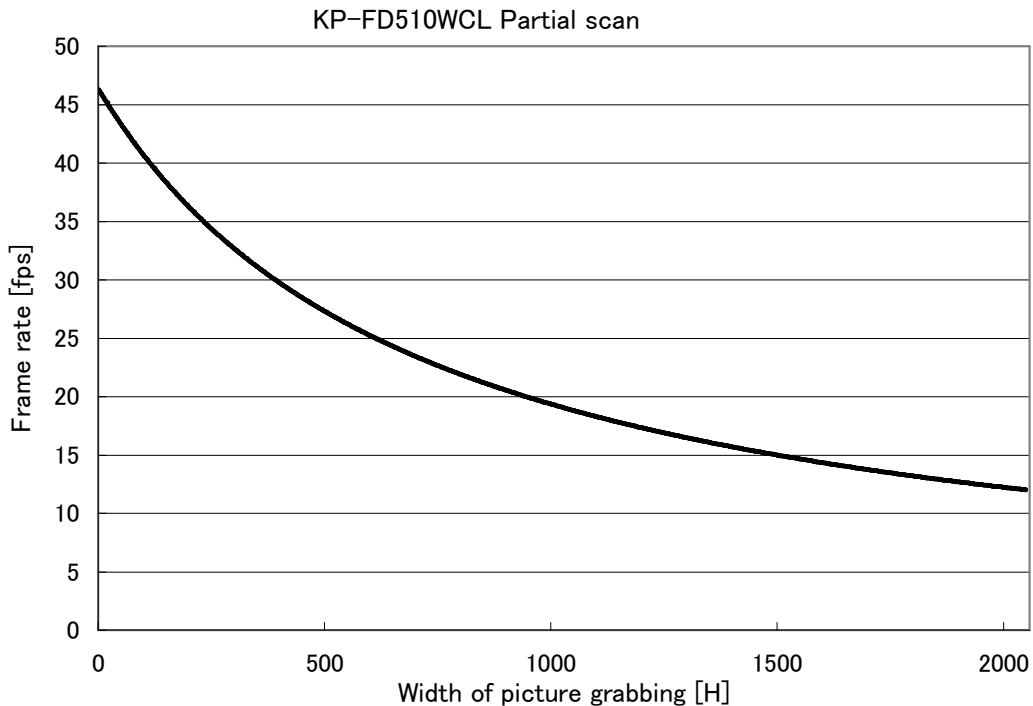

Note: Frame rate can be calculated from following equations using width of picture grabbing.

Lines = $20 + \text{Width} + (2071 - \text{Width}) / 4$

Frame rate = $(48000000 / 1926) / \text{Lines}$

DWG. No.

E400399747

SHEET
12 / 17

8-2. Fixed shutter mode

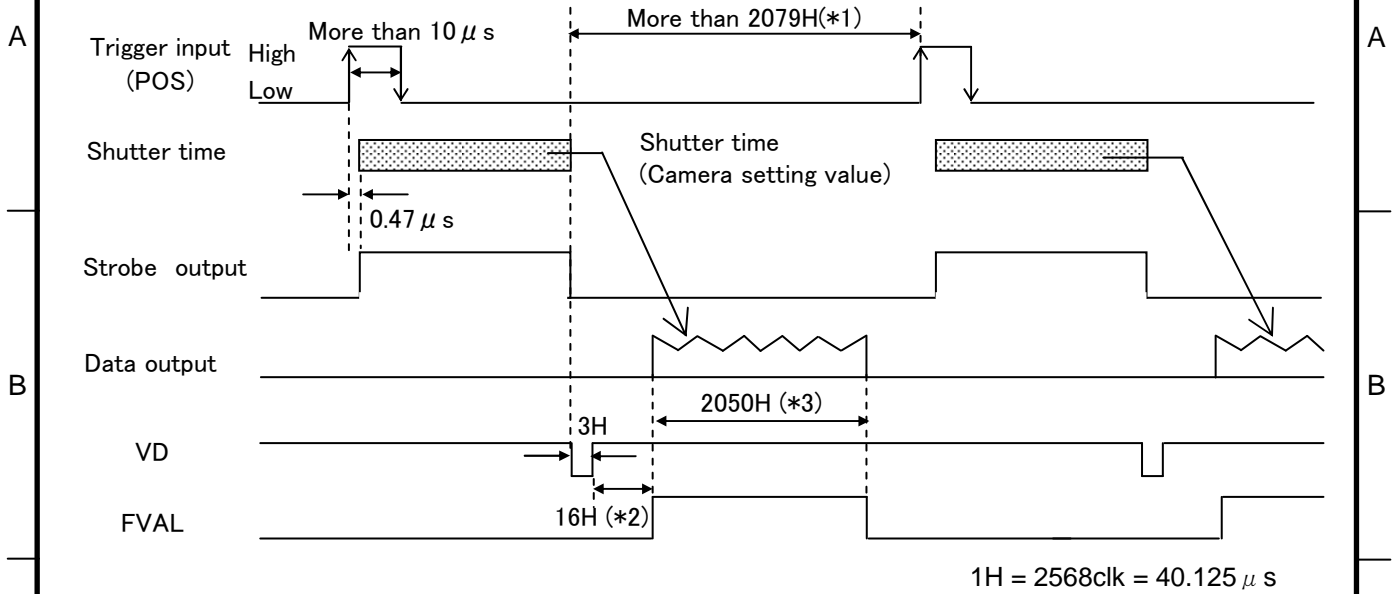

When partial scan is ON, *1 to *3 are variable by start position of picture grabbing and width of picture grabbing (omit the figures after the decimal fractions).

- *1: $(20 + \text{Width} + (2071 - \text{Width}) / 4)H$ or more
- *2: $(16 + \text{Start} / 4)H$
- *3: $(\text{Width})H$

Note1: Please use the partial scan in following condition.
 $\text{Start} + \text{Width} \leq 2051$

Note2: Please use FVAL in the partial scan.

8-3. ONE trigger mode

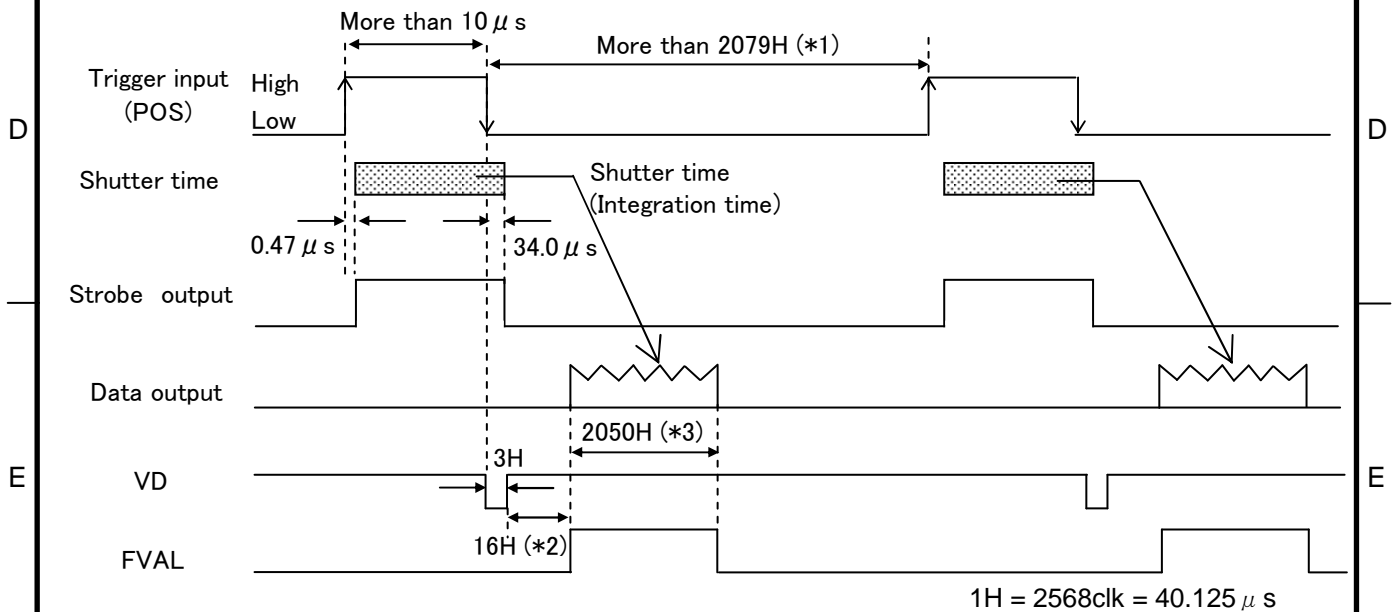

When partial scan is ON, *1 to *3 are variable by start position of picture grabbing and width of picture grabbing (omit the figures after the decimal fractions).

- *1: $(20 + \text{Width} + (2071 - \text{Width}) / 4)H$ or more
- *2: $(16 + \text{Start} / 4)H$
- *3: $(\text{Width})H$

Note1: Please use the partial scan in following condition.
 $\text{Start} + \text{Width} \leq 2051$

Note2: Please use FVAL in the partial scan.

8-4. VD reset mode

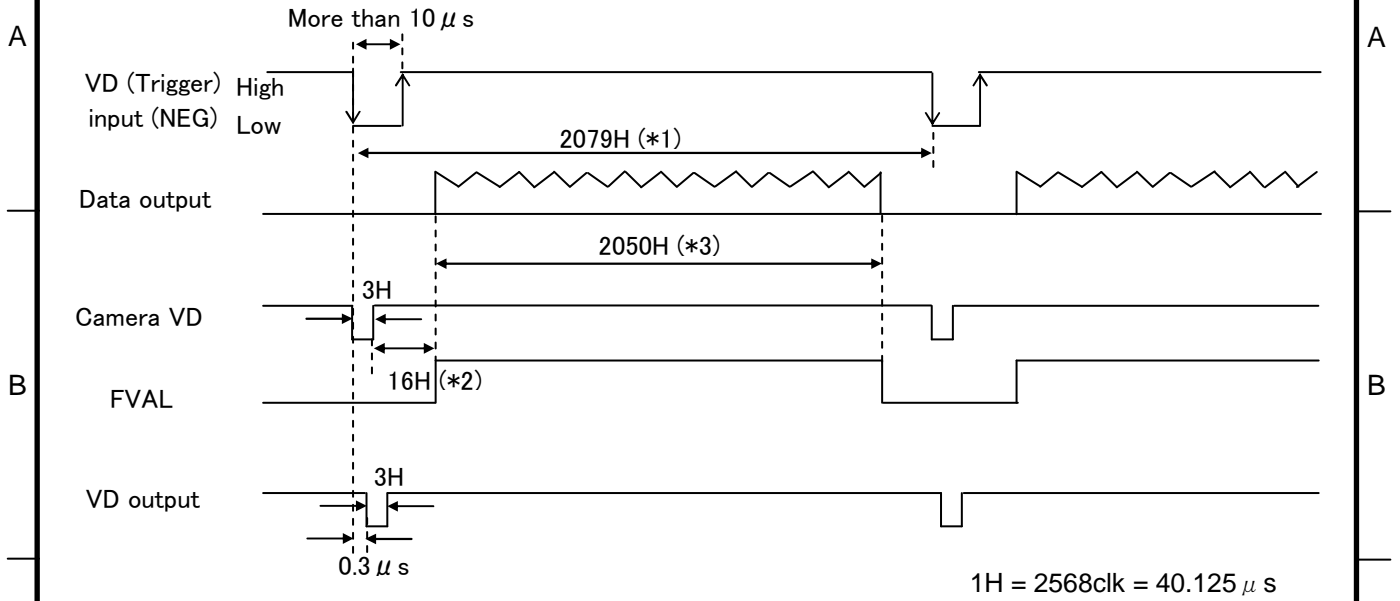

When partial scan is ON, *1 to *3 are variable by start position of picture grabbing and width of picture grabbing (omit the figures after the decimal fractions).

- *1: $(20 + \text{Width} + (2071 - \text{Width}) / 4)H$
- *2: $(16 + \text{Start} / 4)H$
- *3: $(\text{Width})H$

Note1: Please use the partial scan in following condition.
 $\text{Start} + \text{Width} \leq 2051$

Note2: Please use FVAL in the partial scan.

NOTE: If the external VD of cycle which does not match the camera operation mode is input, shutter time has an error.

9. External view

- MASS : APPROX 110 g
- UNIT : mm
- SCALE : NTS

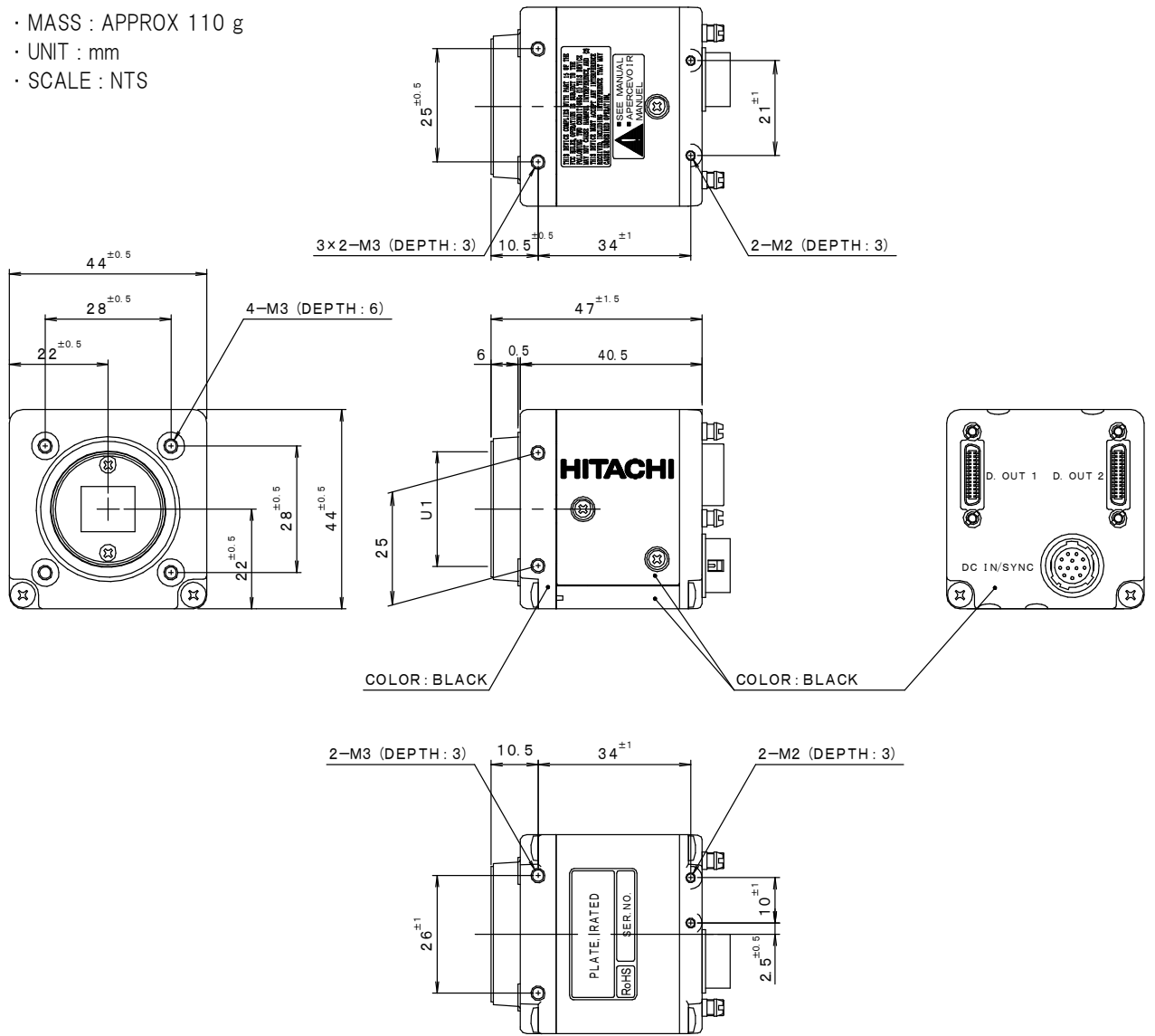

Notice:

These specifications are subject to change without prior notice due to product improvement.

Confirm the most recent specifications at time of order.

Hitachi Kokusai certifies this product complies with the standard warranty conditions of Hitachi Kokusai, and that quality control is implemented to the extent required to comply with these conditions.

RoHS Compliant

This product complies with the requirement of the RoHS(Restriction of the use of Certain Hazardous Substances in Electrical and Electronic Equipment) Directive 2002/95/EC

Warranty and service:

- (1) The guarantee period is one year after the data purchase.
However, the defects due to erroneous use or intentional act are excluded.
- (2) As the defect after expiration of the guarantee period, where product repair is possible, repair will be performed at charge.
- (3) The present Warranty pertains only to the camera unit. Secondary malfunctions attributable to camera failure as well as expenses incurred by disassembly and reassembly of the related system, are beyond the scope of this Warranty.
- (4) Compensation for loss of business, loss or damage to software, database and other contingent losses are beyond the scope of this Warranty.
- (5) Hitachi Kokusai Electric Inc. is not liable for the losses caused when the equipment is used in a system, use for business trades, production process, medical fields, crime prevention applications, etc.
- (6) In the case of camera trouble by miss wiring of cable, it will be considered as out of warranty.

