

Progressive scan CCD camera KP-F31PCL/SCL Specifications

1. General

The KP-F31PCL/SCL are a CameraLink output system progressive scan black and white CCD camera with a 1/3-inch size CCD and a full frame shutter.

The image of 659 (H) x 494 (V) is output at 120 frames per second.

The square format picture elements provide suitability for image processing applications.

2. Outstanding features

(1) High speed

The image of 659 (H) x 494 (V) active pixels is output in high-speed 120 frames per second.

(2) Small-sized camera

The camera has small SDR connector for digital outputs.

Therefore, the camera has the realization of small-sized shape of 29 (W) x 29 (H) x 38 (D) mm.

(3) Remote control

- Multi-step electronic shutter (from 1/120 to 1/50000 second in 8 steps)

- Variable shutter (minimum 1/100000 second)

- Frame on demand (the image capture at desired timing using the external trigger signal)

and other various functions are set by remote control via CameraLink cable.

(4) Power over CameraLink

Power supply of KP-F31PCL is input via CameraLink cable.

(Note: Power supply of KP-F31SCL is input from DCIN connector.)

-	Sep.14,2007	(first edition)	N.Abe	K.Ueno
SYMBOL	DATE	DESCRIPTION	(DRAWN)	DESIGNED

MODEL KP-F31PCL/SCL				TOLERANCE	Prod. Code - Order No.	
DESIGNED	DATE	APPROVED	DATE	UNIT SCALE	TITLE KP-F31PCL/SCL Specifications	REV. 0
CHECKED	DATE	STORED	DATE			
Hitachi Kokusai Electric						

3. Specifications

A	(1) Imaging device	1/3-inch interline CCD	A
	Total pixels	692 (H) x 504 (V)	
B	Effective pixels	659 (H) x 494 (V)	B
	Pixel size	7.4 um (H) x 7.4 um (V) (square lattice)	
	(2) Sensing area	4.88 mm (H) x 3.66 mm (V)	
	(3) Scanning system	Progressive	
	(4) Aspect ratio	4 : 3	
	(5) Frame rate	120 frames per second (full pixel readout) 219 frames per second (vertical 2 pixel addition)	
	(6) Horizontal drive frequency	49.090902 MHz	
	(7) Horizontal scanning frequency	62.937 kHz (full pixel readout) 57.618 kHz (vertical 2 pixel addition)	
	(8) Vertical scanning frequency	119.88 Hz (full pixel readout) 219.08 Hz (vertical 2 pixel addition)	
	C	(9) Sync system	
(10) Lens mount		C mount	
(11) Flange focal distance		17.526 mm	
(12) Video output		Digital output (CameraLink) Base configuration: 24.545451 MHz x 2 TAP (Note: maximum cable length is 10 m) Output image size: 659 (H) x 494 (V) (full pixel readout)	
D	(13) Resolution	Horizontal: 500 TV lines / Vertical: 490 TV lines	D
	(14) Sensitivity	550 lx, F4, 3200 K	
	(15) Minimum illumination	8.6 lx (F1.4, MAX GAIN)	
	(16) Signal noise to ratio	50 dB	
	(17) Electric shutter	OFF, 1/120, 1/250, 1/500, 1/1000, 1/2000, 1/4000, 1/10000, 1/50000 second OFF is normal exposure (frame rate) or changeable by variable shutter (minimum 1/100000 second)	
	(18) Gamma	= 1	
	(19) Frame on demand	(A) Fixed shutter mode (8 steps or variable) (B) ONE trigger mode	
E	(20) Partial scan	Selectable start position and width of picture grabbing in 1H step.	E
	(21) Power supply voltage	12 ± 1 VDC	
	(22) Current consumption	Approx. 190 mA (approx. 2.3 W) *MAX partial scan 1H: Approx. 230 mA (approx. 2.8W)	
F			F

	1	2	3	4			
A	(23) Ambient	Performance	0 to +40	(+32 to +104 F), less than 90 % RH	A		
		Operation	-10 to +50	(+14 to 122 F), less than 90 % RH			
		Storage	-20 to +60	(-4 to 140 F), less than 70 % RH (without dew condensation)			
B	(24) Vibration endurance		98 m/s ² (Acceleration: constant)		B		
			10 to 200 Hz, sweep: 10 minutes, XYZ 30 minutes				
	(25) Shock endurance		686 m/s ² (Drop test, once each top, bottom, left and right)				
	(26) External dimensions		29 (W) x 29 (W) x 38 (D) mm (Not including protrusions)				
	(27) Mass		Approx. 50 g				
	C	(28) Remote control	(a) Signal system				C
			Control system			Start-stop synchronization system	
		Transmission rate		9600 bps			
		Data length		8 bits			
		Start bit		1 bit			
Stop bit			1 bit				
Parity			None				
Bit transfer			LSB first				
(b) Communications control system							
Full control by remote control software, data send/receive by text data transfer to camera Microprocessor (BSC system handshake).							
D	(c) Control items	1. Shutter speed		OFF, 1/120, 1/250, 1/500, 1/1000, 1/2000, 1/4000, 1/10000, 1/50000 second	D		
				Factory setting: OFF			
	2. Variable shutter		Minimum 1/100000 second				
	3. Mode		OFF, Fixed shutter and ONE trigger mode				
			Factory setting: OFF				
	4. Gain		0 to 12 dB (Approx. 0.0358 dB step)				
			Factory setting: 0dB				
	5. VD / FVAL		Factory setting: FVAL				
	6. HD / LVAL		Factory setting: LVAL				
	7. 8bit / 10bit		Factory setting: 10bit				
8. Partial scan		Factory setting: OFF					
9. Vertical 2 pixel addition mode		Factory setting: OFF					
10. Trigger pulse polarity		Factory setting: POS					
E					E		
F					F		

4. Composition

- (1) Camera (with dummy glass)
 (2) Operation manual

5. Optional accessories

- (1) Dummy glass (AR coated) ARC1214
 (2) IR cut filter IRC650
 (3) Junction box (for KP-F31SCL) JU-M1A, JU-F1
 (4) Tripod adaptor TA-F230
 (5) 12pin plug (for KP-F31SCL) HR10A-10P-12S(01)
 (6) Camera cable (for KP-F31SCL)

	Molded type	Shield type
2 m	C-201KSM	C-201KSS
5 m	C-501KSM	C-501KSS
10 m	C-102KSM	C-102KSS

In the CE Marking region, use the shield type.

(7) Digital out cable

- Mini CameraLink cable(for KP-F31SCL) SDR-MDR type

Cable length	Model name
1m	C-101SCL
2m	C-201SCL
3m	C-301SCL
5m	C-501SCL
10m	C-102SCL

- PoCL cable(for KP-F31PCL)

Cable length	Model name	
	SDR-SDR type	SDR-MDR type
1m	C-101PCL (SS)	C-101PCL (SM)
2m	C-201PCL (SS)	C-201PCL (SM)
3m	C-301PCL (SS)	C-301PCL (SM)
5m	C-501PCL (SS)	C-501PCL (SM)
10m	C-102PCL (SS)	C-102PCL (SM)

SDR: Shrunken Delta Ribbon

MDR: Miniature Delta Ribbon

6. Signal connection to connector

Pin No.	Signal	Pin No.	Signal
1	+12V (KP-F31PCL)	14	GND
	GND (KP-F31SCL)		
2	TXOUT 0 (-)	15	TXOUT 0 (+)
3	TXOUT 1 (-)	16	TXOUT 1 (+)
4	TXOUT 2 (-)	17	TXOUT 2 (+)
5	TXCLKOUT (-)	18	TXCLKOUT (+)
6	TXOUT 3 (-)	19	TXOUT 3 (+)
7	RX (+) [SERTC (+)]	20	RX (-) [SERTC (-)]
8	TX (-) [SERTFG (-)]	21	TX (+) [SERTFG (+)]
9	TRIG (-) [CC1 (-)]	22	TRIG (+) [CC1 (+)]
10	N.U. [CC2 (+)]	23	N.U. [CC2 (-)]
11	N.U. [CC3 (-)]	24	N.U. [CC3 (+)]
12	N.U. [CC4 (+)]	25	N.U. [CC4 (-)]
13	GND	26	+12V (KP-F31PCL)
			GND (KP-F31SCL)

Connector (camera side) SDR connector (Sumitomo 3M) or equivalent

N.U.: Not used

- The digital out cable should be comprised of a twisted pair of wires having 100 ohm characteristic impedance and an outer sheath shield type conductor.
- Connect the shield (ground) of the digital out cable to the ground terminal of the video equipment, frame grabber, etc.
- Install clamp filter (ZCAT3035-1330: TDK) at both ends (camera and video processor ends) in the CE marking region.
- TX: Transmit data from camera to machine
- RX: Transmit data from machine to camera

(Note) Please do not unplug and insert cable (digital out cable) with a power supplied to a camera.

(Note) Power of KP-F31SCL is input from DCIN connector.

Pin No.2, 11: +12V

Pin No.1, 10: GND

Pin No.3, 4, 5, 6, 7, 8, 9, 12: Not used

7. CameraLink output

7-1. Horizontal timing

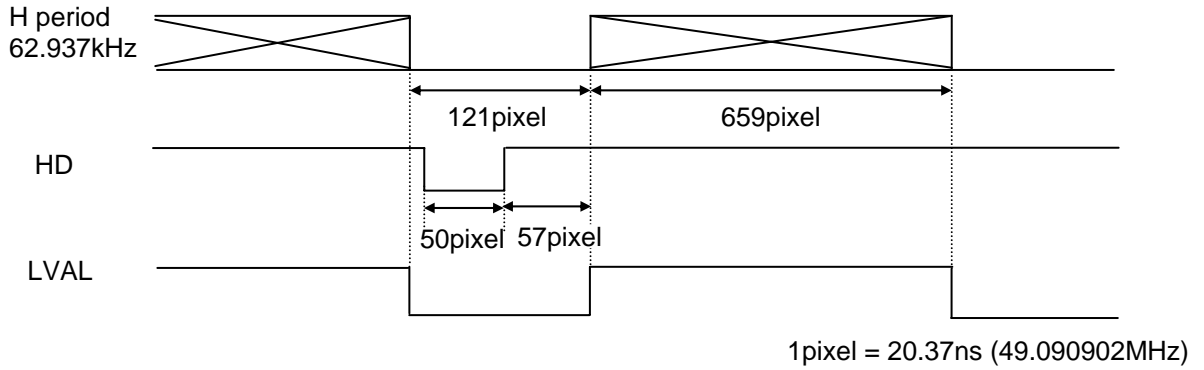

7-2. Vertical timing

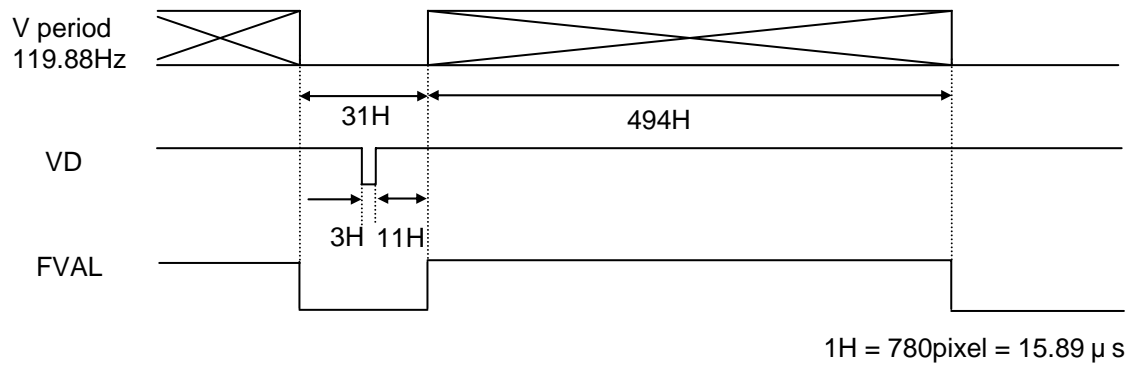

7-3. Horizontal timing for vertical 2 pixel addition mode

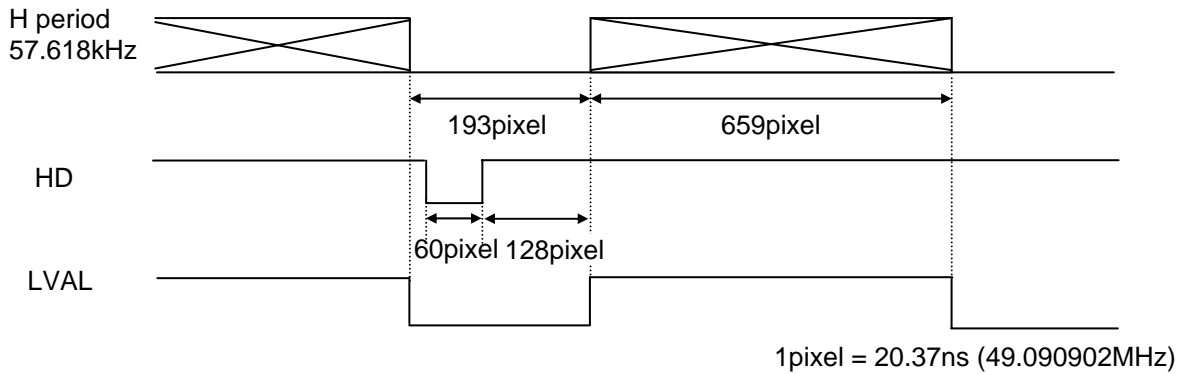

7-4. Vertical timing for vertical 2 pixel addition mode

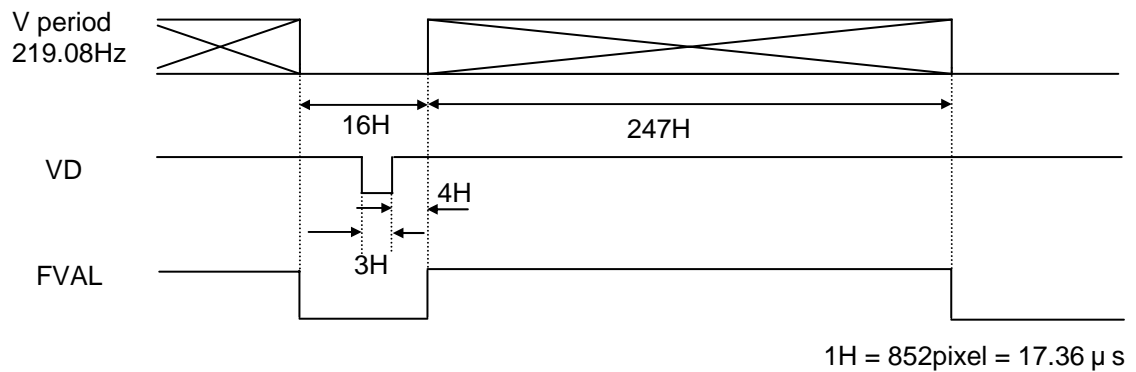

7-3. Transmitter LVDS output pulse position measurement

A

(1) 10bit

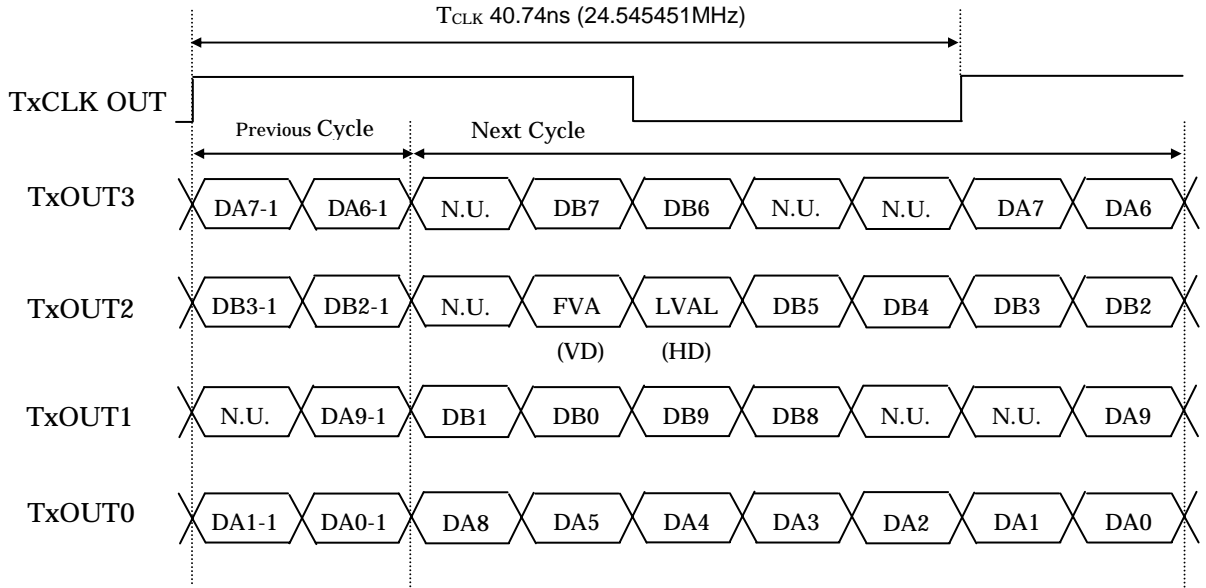

N.U.: Not used

C

(2) 8bit

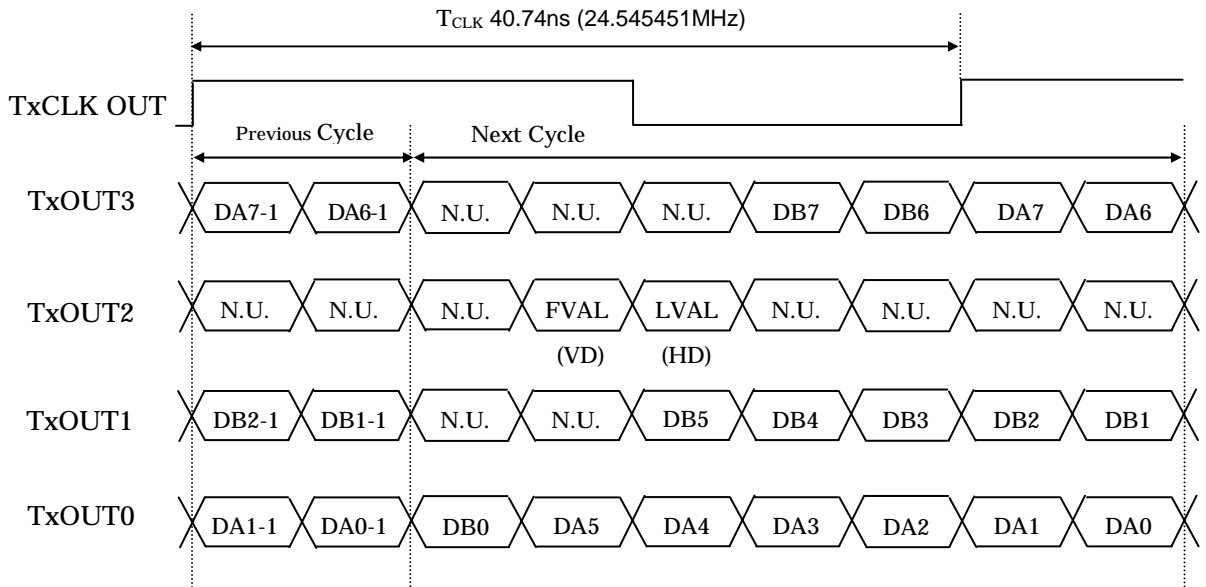

N.U.: Not used

D

E

F

8. Timing chart

8-1. Normal mode

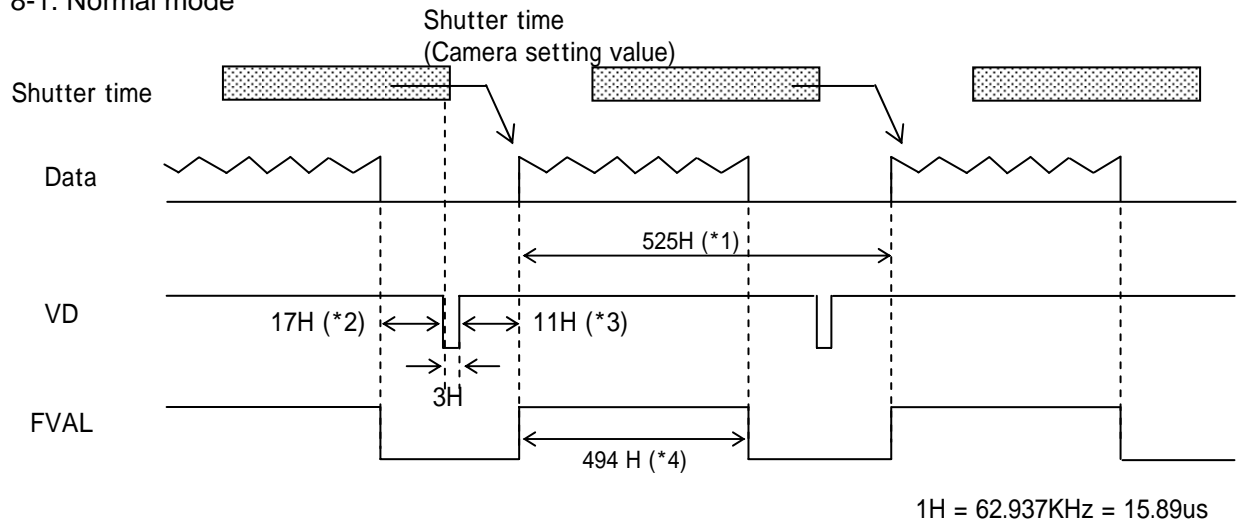

When partial scan is ON, *1 to *4 are variable by start position of picture grabbing and width of picture grabbing (omit the figures after the decimal fractions).

*1: $(17 + \text{Width} + (510 - \text{Width}) / 5)H$

*2: $(3 + (510 - \text{Width}) / 5 - \text{Start} / 5)H$

*3: $(11 + \text{Start} / 5)H$

*4: $(\text{Width})H$

Note1: Please use the partial scan in following condition.

$$\text{Start} + \text{Width} = 495$$

Note2: Please use FVAL in the partial scan.

Graph following shows frame rate in each width of picture grabbing.

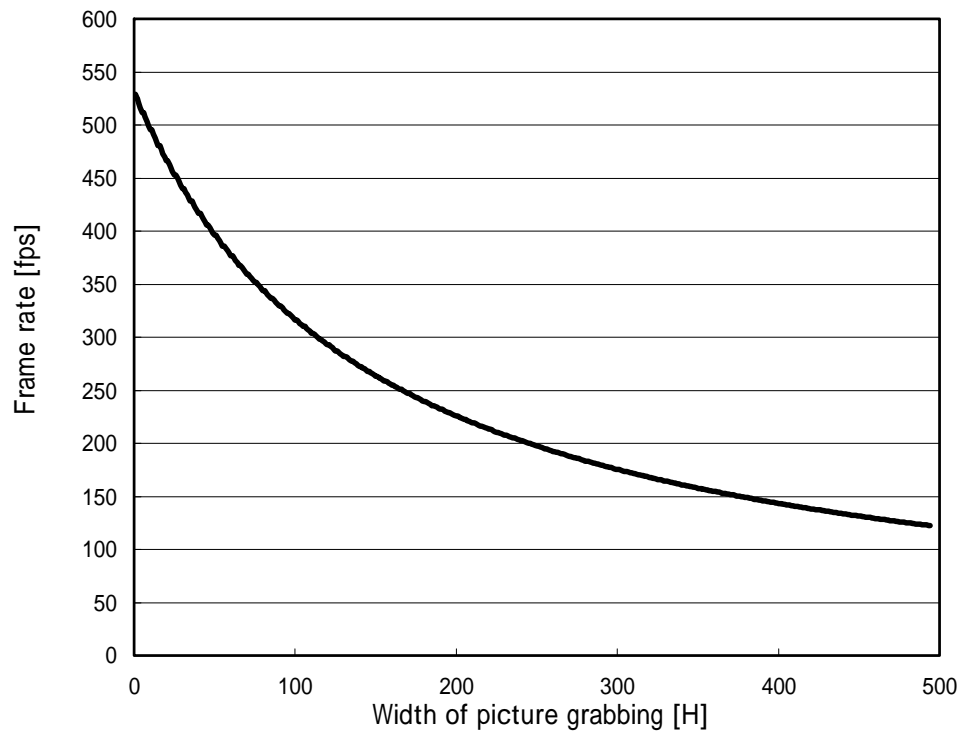

Note: Frame rate can be calculated from following equations using width of picture grabbing.

$$\text{Lines} = 17 + \text{Width} + (510 - \text{Width}) / 5$$

$$\text{Frame rate} = (49090902 / 780) / \text{Line}$$

DWG.
No.

E400084809

SHEET
8 / 14

8-2. Fixed shutter mode

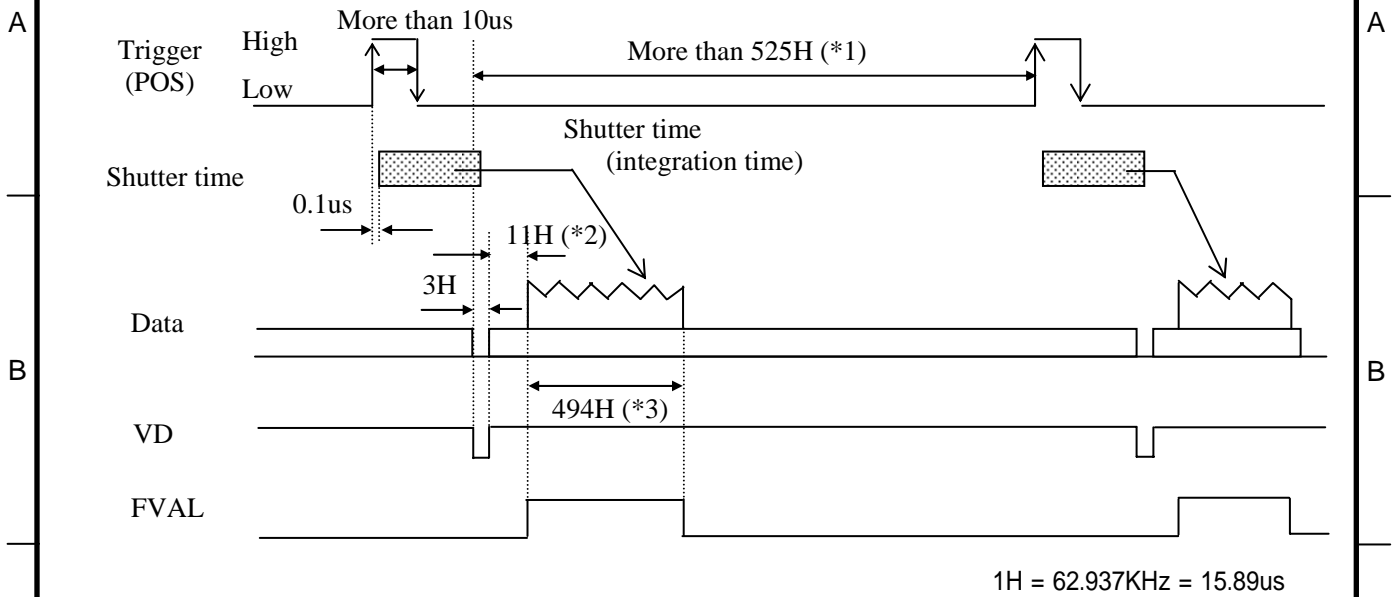

When partial scan is ON, *1 to *3 are variable by start position of picture grabbing and width of picture grabbing (omit the figures after the decimal fractions).

*1: $(17 + \text{Width} + (510 - \text{Width}) / 5)H$ or more

*2: $(11 + \text{Start} / 5)H$

*3: $(\text{Width})H$

Note1: Please use the partial scan in following condition.

Start + Width 495

Note2: Please use FVAL in the partial scan.

8-3. ONE trigger mode

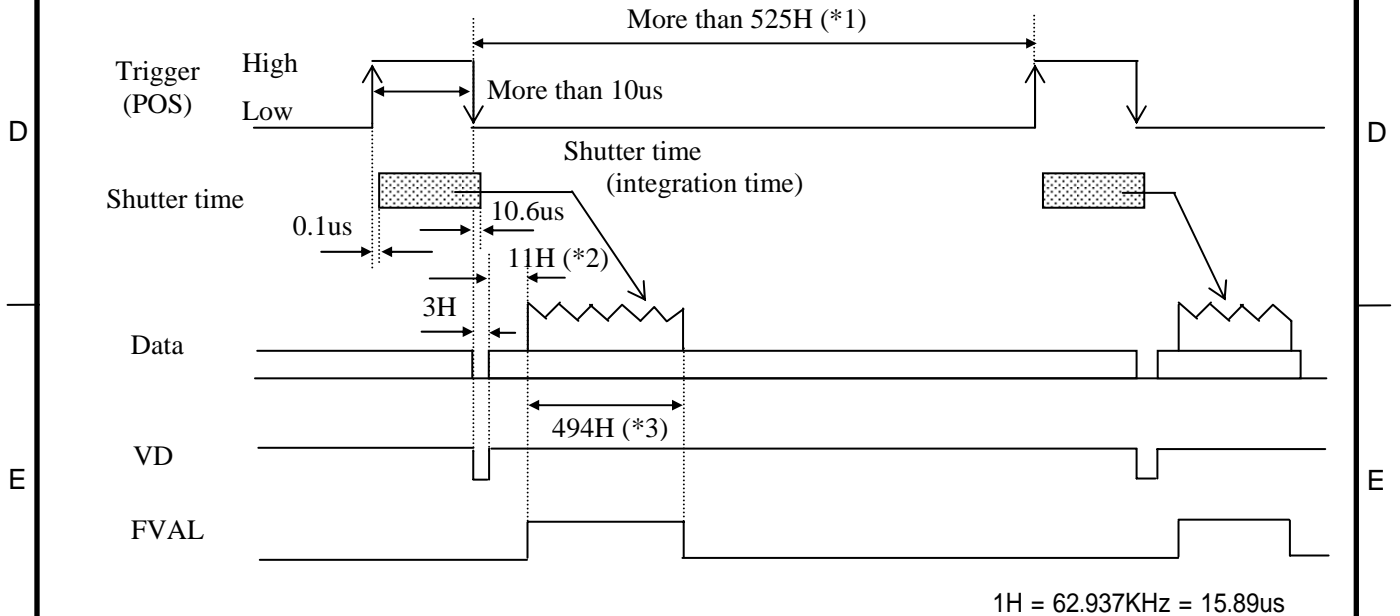

When partial scan is ON, *1 to *3 are variable by start position of picture grabbing and width of picture grabbing (omit the figures after the decimal fractions).

*1: $(17 + \text{Width} + (510 - \text{Width}) / 5)H$ or more

*2: $(11 + \text{Start} / 5)H$

*3: $(\text{Width})H$

Note1: Please use the partial scan in following condition.

Start + Width 495

Note2: Please use FVAL in the partial scan.

9. Spectral response

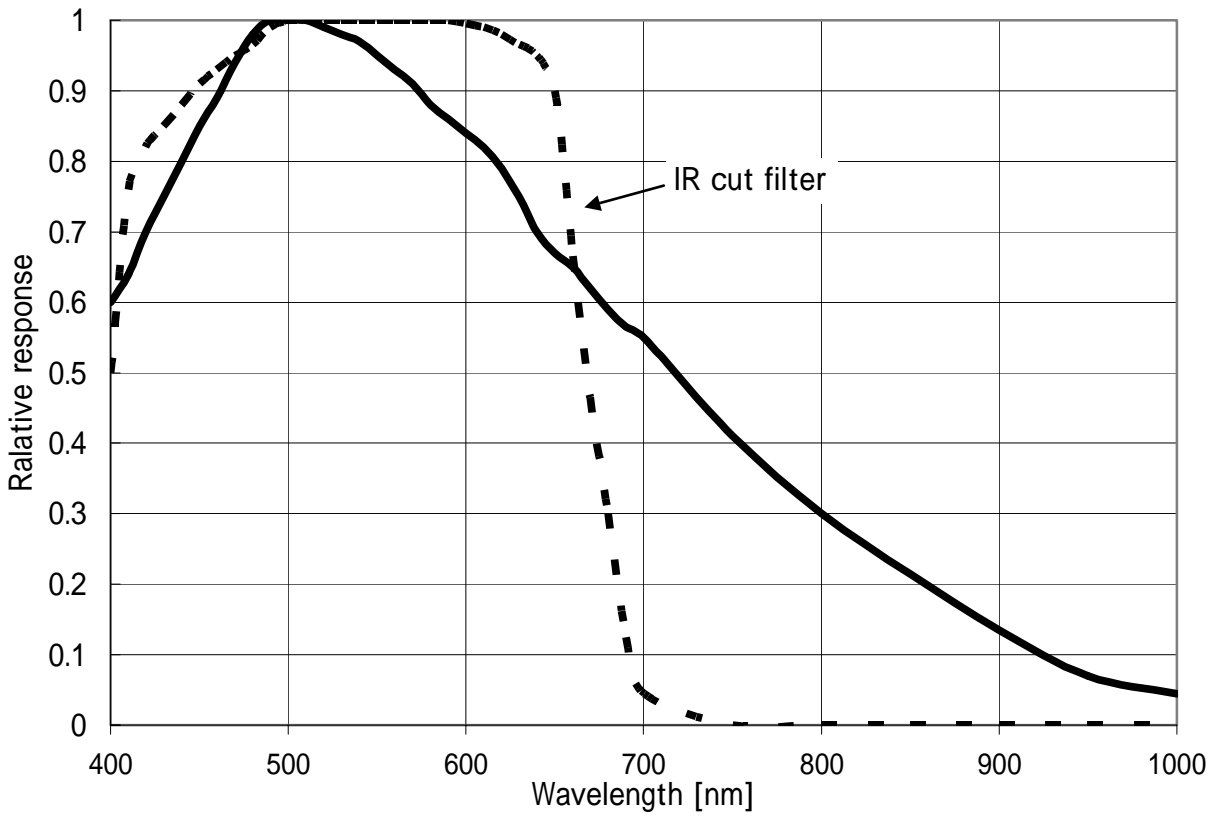

10. External view

A

10-1. KP-F31PCL

- MASS : APPROX 50 g
- COLOR: BLACK
- TOLERANCE : ±0.5
- UNIT : mm

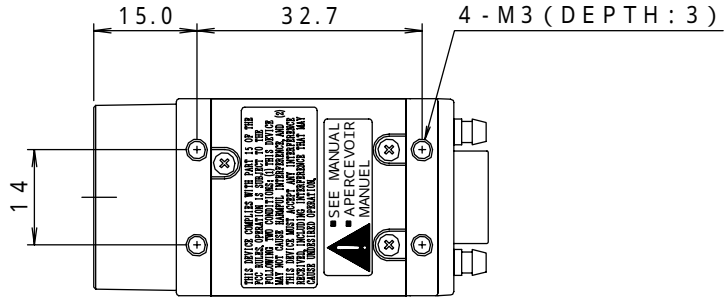

B

C

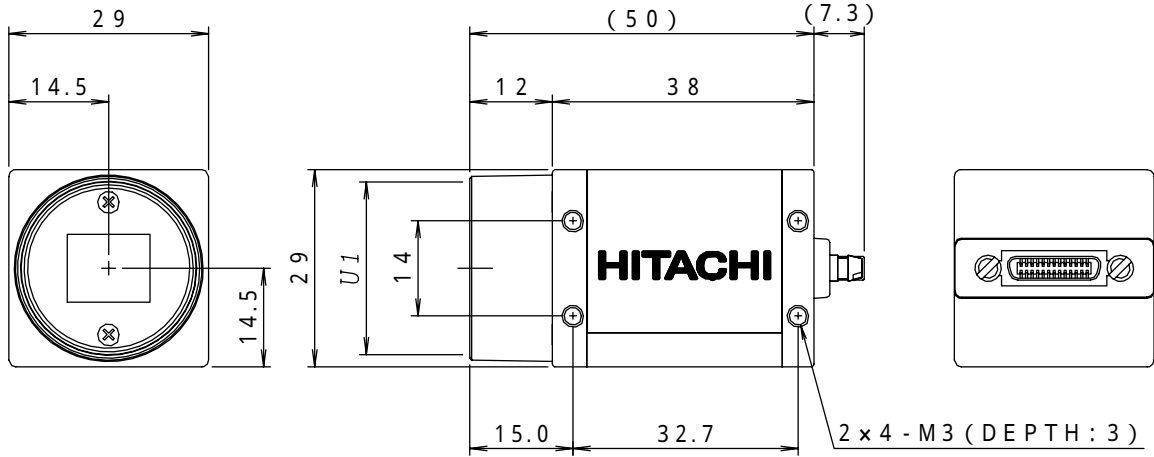

D

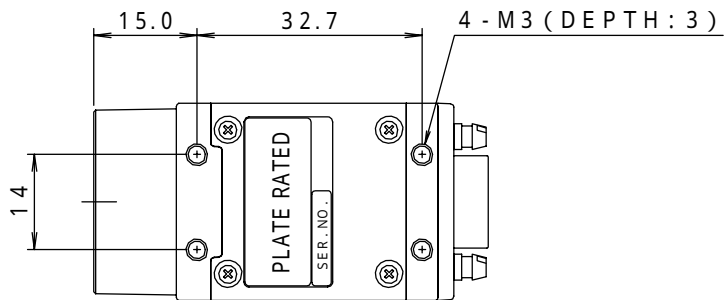

E

F

10-2. KP-F31SCL

- MASS : APPROX 50 g
- COLOR: BLACK
- TOLERANCE : ± 0.5
- UNIT : mm

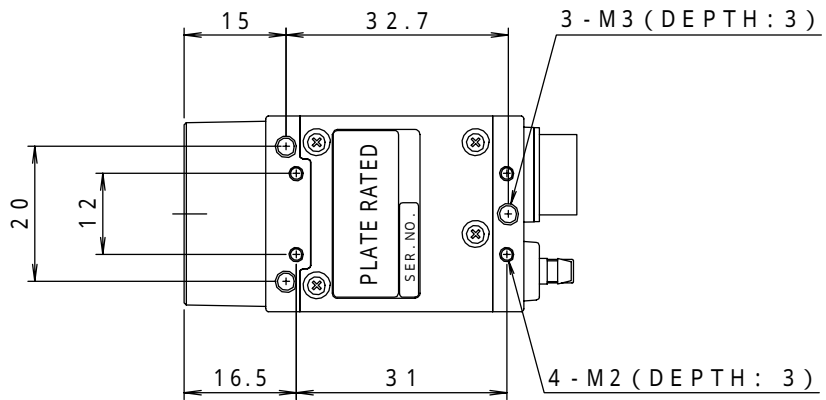
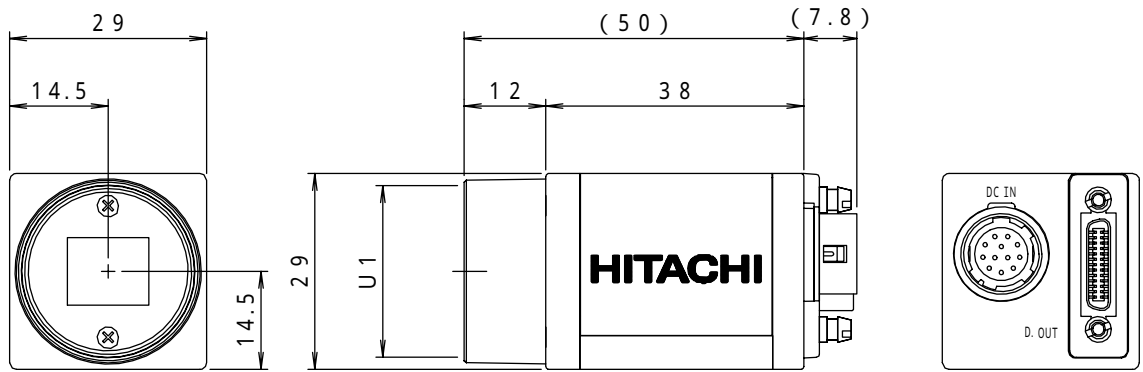
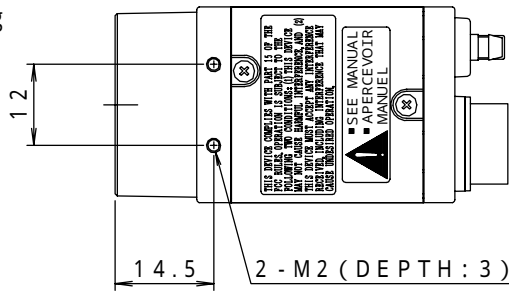

Notice:

These specifications are subject to change without prior notice due to product improvement.

Confirm the most recent specifications at time of order.

Hitachi Kokusai certifies this product complies with the standard warranty conditions of Hitachi Kokusai, and that quality control is implemented to the extent required to comply with these conditions.

RoHS Compliant

This product complies with the requirement of the RoHS(Restriction of the use of Certain Hazardous Substances in Electrical and Electronic Equipment) Directive 2002/95/EC

Warranty and service:

- (1) The guarantee period is one year after the data purchase.
However, the defects due to erroneous use or intentional act are excluded.
- (2) As the defect after expiration of the guarantee period, where product repair is possible, repair will be performed at charge.
- (3) The present Warranty pertains only to the camera unit. Secondary malfunctions attributable to camera failure as well as expenses incurred by disassembly and reassembly of the related system, are beyond the scope of this Warranty.
- (4) Compensation for loss of business, loss or damage to software, database and other contingent losses are beyond the scope of this Warranty.
- (5) Hitachi Kokusai Electric Inc. is not liable for the losses caused when the equipment is used in a system, use for business trades, production process, medical fields, crime prevention applications, etc.
- (6) In the case of camera trouble by miss wiring of cable, it will be considered as out of warranty.

